

OPERATION MANUAL



Hydraulic & Pneumatic Shop Press

Model

HPM-100P

Order Code P156

EDITION No : HPH-100P-1

DATE OF ISSUE : 01-2024

MACHINE DETAILS

MACHINE	Air/Hydraulic Shop Press
MODEL NO.	HPM -100P
SERIAL NO.	
DATE OF MANF.	

DISTRIBUTED BY



NOTE:
This manual is only for your reference. At the time of the compiling of this manual every effort to be exact with the instructions, specifications, drawings, and photographs of the machine was taken. Owing to the continuous improvement of the HAFCO METALMASTER machine, changes may be made at any time without obligation or notice. Please ensure the local voltage is the same as listed on the specification plate before operating any electric machine.

SAFETY SYMBOLS

The purpose of safety symbols is to attract your attention to possible hazardous conditions

WARNING *Indicates a potentially hazardous situation causing injury or death*

CAUTION *Indicates an alert against unsafe practices.*

Note: Used to alert the user to useful information

NOTE:
In order to see the type and model of the machine, please see the specification plate. Usually found on the back of the machine. See example (Fig.1)

FIG. 1

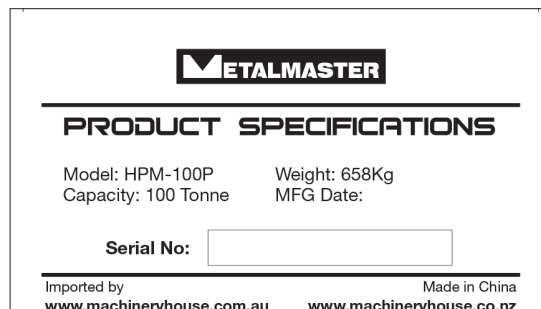

CONTENTS

1. GENERAL MACHINE INFORMATION	
1.1 Specifications.....	4
1.2 Accessories Included.....	4
1.3 Identification.....	5
2. IMPORTANT INFORMATION	
2.1 General Workshop Safety.....	6
2.2 Specific Safety for Hydraulic Press.....	9
2.3 Lifting Instructions.....	10
Lifting Points	
3. INSTALLATION	
3.1 Site Preparation.....	11
3.2 Options For Mounting.....	11
3.3 Assembly.....	12
Pressure Gauge Assembly	
Pump Assembly	
4. OPERATION	
4.1 Commissioning.....	14
Purging The System	
4.2 Positioning the Bed.....	15
4.3 Positioning the Ram.....	15
4.4 Pressing Process.....	16
5. MAINTENANCE	
5.1 Inspection Schedule.....	17
5.2 Troubleshooting.....	17
5.3 Changing The Hydraulic Oil.....	18
5.4 Possible Maintenance.....	18
Pump Oil Leakage	
Press Not Holding Pressure	
Spare Parts.....	19
Risk Assessment Sheets.....	29

1.1 SPECIFICATION

Order Code	P156
MODEL	HPM-100P
(Tonne) Pressing Capacity	100
(Type) Hydraulic Ram Operation	Hydraulic & Pneumatic
(Yes / No) Sliding Ram (left-right)	Yes
(mm) Width Between Front Posts	787
(mm) Width Between Side Posts	265
(mm) Table Top Opening - (Front to Back)	230
(mm) Ram To Table (Max.)	993
(mm) Cylinder Stroke	300
(mm) Ram Diameter	Ø100
(mm) Floor Space (W x D x H)	1200 x 990 x 1837
(kg) Nett Weight	658

1.2 ACCESSORIES INCLUDED

- Heavy duty vee blocks
- Instruction Manual



WARNING

The machine is the sole responsibility of the owner for its safe use. This responsibility includes but is not limited to proper installation in a safe environment, personnel training, proper inspection and maintenance, manual availability and comprehension. The manufacturer will not be held liable for injury or property damage from negligence, improper training, machine modifications or misuse.

1.3 IDENTIFICATION

Become familiar with the names and locations of the controls and features shown below to better understand the instructions in this manual.

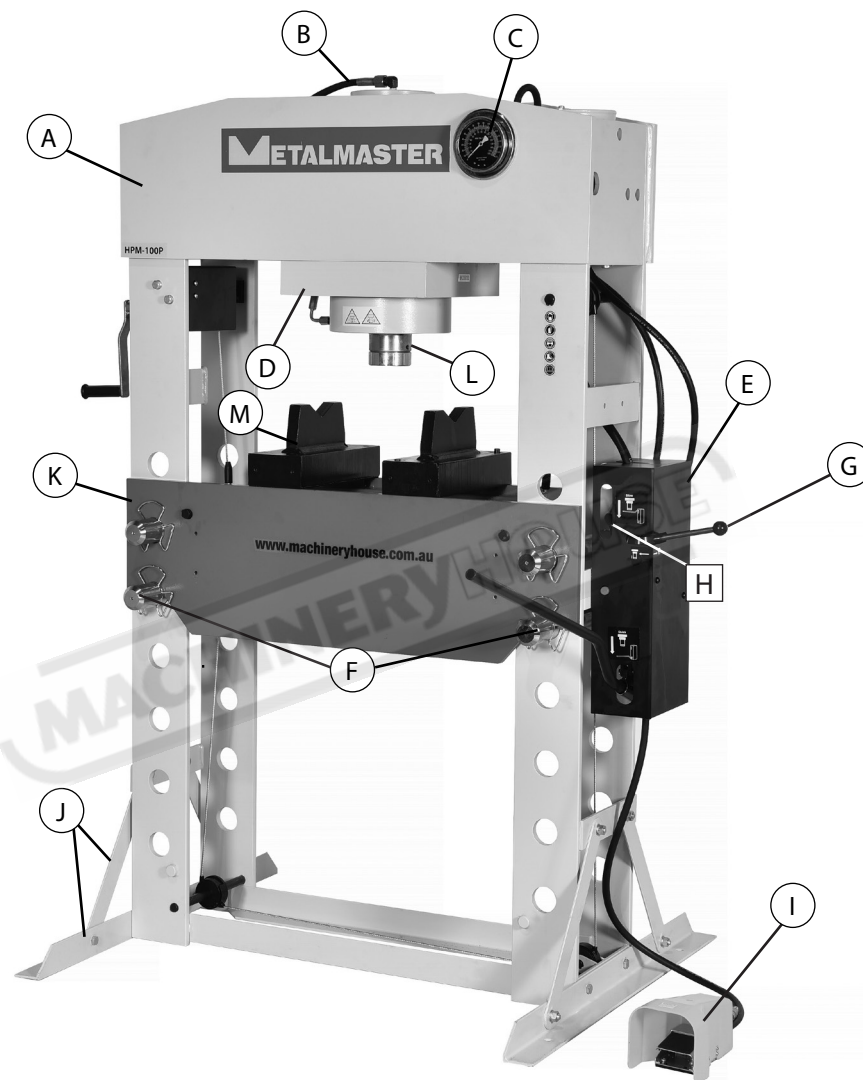

A	Main Frame	H	Pressure Release Valve
B	Cylinder	I	Press Operating Pedal
C	Pressure Gauge	J	Press Feet & Stay Bars
D	Ram Baseplate	K	Bed or Working Table
E	Hydraulic Pump	L	Ram
F	Safety Pins with Safety Clips	M	Pressing Plates
G	Operating Handle		

2.1 GENERAL METALWORKING MACHINE SAFETY

DO NOT use this machine unless you have read this manual or have been instructed in the safe use and operation of this machine.



WARNING

This manual provides safety instructions on the proper setup, operation, maintenance, and service of this machine. Save this manual, refer to it often, and use it to instruct other operators. Failure to read, understand and follow the instructions in this manual may result in fire or serious personal injury—including amputation, electrocution, or death.

The owner of this machine is solely responsible for its safe use. This responsibility includes, but is not limited to proper installation in a safe environment, personnel training and authorization to use, proper inspection and maintenance, manual availability and comprehension of the application of the safety devices, integrity, and the use of personal protective equipment.

The manufacturer will not be held liable for injury or property damage from negligence, improper training, machine modifications or misuse.



- ✓ Always wear safety glasses or goggles.
- ✓ Wear appropriate safety footwear.
- ✓ Wear respiratory protection where required.
- ✓ Gloves should never be worn while operating the machine, and only worn when handling the workpiece.
- ✓ Wear hearing protection in areas > 85 dBA. If you have trouble hearing someone speak from one metre (three feet) away, the noise level from the machine may be hazardous.
- ✓ DISCONNECT THE MACHINE FROM POWER when making adjustments or servicing.
- ✓ Check and adjust all safety devices before each job.
- ✓ Ensure that guards are in position and in good working condition before operating.
- ✓ Ensure that all stationary equipment is anchored securely to the floor.
- ✓ Ensure all machines have a start/stop button within easy reach of the operator.
- ✓ Each machine should have only one operator at a time. However, everyone should know how to stop the machine in an emergency.

2.1 GENERAL METALWORKING MACHINE SAFETY Cont.

- ✓ Ensure that keys and adjusting wrenches have been removed from the machine before turning on the power. Appropriate storage for tooling should be provided.
- ✓ Ensure that all cutting tools and blades are clean and sharp. They should be able to cut freely without being forced.
- ✓ Stop the machine before measuring, cleaning or making any adjustments.
- ✓ Wait until the machine has stopped running to clear cuttings with a vacuum, brush or rake.
- ✓ Keep hands away from the cutting head and all moving parts.
- ✓ Avoid awkward operations and hand positions. A sudden slip could cause the hand to move into the cutting tool or blade.
- ✓ Return all portable tooling to their proper storage place after use.
- ✓ Clean all tools after use.
- ✓ Keep work area clean. Floors should be level and have a non-slip surface.
- ✓ Use good lighting so that the work piece, cutting blades, and machine controls can be seen clearly. Position any shade lighting sources so that they do not cause any glare or reflections.
- ✓ Ensure there is enough room around the machine to do the job safely.
- ✓ Obtain first aid immediately for all injuries.
- ✓ Understand that the health and fire hazards can vary from material to material. Make sure all appropriate precautions are taken.
- ✓ Clean machines and the surrounding area when the operation is finished.
- ✓ Use proper lock out procedures when servicing or cleaning the machines or power tools.

DO NOT

- ✗ Do not distract an operator. Horseplay can lead to injuries and should be strictly prohibited.
- ✗ Do not wear loose clothing, gloves, neckties, rings, bracelets or other jewellery that can become entangled in moving parts. Confine long hair.
- ✗ Do not handle cuttings by hand because they are very sharp. Do not free a stalled cutter without turning the power off first. Do not clean hands with cutting fluids.
- ✗ Do not use rags or wear gloves near moving parts of machines.
- ✗ Do not use compressed air to blow debris from machines or to clean dirt from clothes.
- ✗ Do not force the machine. It will do the job safer and better at the rate for which it was designed.



WARNING!

People with pacemakers should consult their physician(s) before use. Electromagnetic fields in close proximity to heart pacemaker could cause pacemaker interference or pacemaker failure.



WARNING.

Before operating any machine, take time to read and understand all safety signs and symbols. If not understood seek explanation from your supervisor.

2.1 GENERAL METALWORKING MACHINE SAFETY Cont.

HAZARDS ASSOCIATED WITH MACHINES include, but are not limited to:

- Being struck by ejected parts of the machinery
- Being struck by material ejected from the machinery
- Contact or entanglement with the machinery
- Contact or entanglement with any material in motion

HEALTH HAZARDS (other than physical injury caused by moving parts)

- Chemicals hazards that can irritate, burn, or pass through the skin
- Airborne items that can be inhaled, such as oil mist, metal fumes, solvents, and dust
- Heat, noise, and vibration
- Ionizing or non-ionizing radiation (X-ray, lasers, etc.)
- Biological contamination and waste
- Soft tissue injuries (for example, to the hands, arms, shoulders, back, or neck) resulting from repetitive motion, awkward posture, extended lifting, and pressure grip.

OTHER HAZARDS

- Slips and falls from and around machinery during maintenance
- Unstable equipment that is not secured against falling over
- Safe access to/from machines (access, egress)
- Fire or explosion
- Pressure injection injuries from the release of fluids and gases under high pressure
- Electrical Hazards, such as electrocution from faulty or ungrounded electrical components
- Environment in which the machine is used (in a machine shop, or on a work site)



WARNING

The machine is the sole responsibility of the owner for its safe use. This responsibility includes but is not limited to proper installation in a safe environment, personnel training, proper inspection and maintenance, manual availability and comprehension. The manufacturer will not be held liable for injury or property damage from negligence, improper training, machine modifications or misuse.



WARNING!

Machines are safeguarded to protect the operator from injury or death with the placement of guards. Machines must not be operated with the guards removed or damaged.

2.2 SPECIFIC SAFETY FOR HYDRAULIC PRESS

DO NOT use this machine unless you have been instructed in its safe use and operation and have read and understood this manual



Safety glasses must be worn at all times in work areas



Close fitting/protective clothing must be worn



Sturdy footwear must be worn at all times in work areas



Rings and jewellery must not be worn.

PRE-OPERATIONAL SAFETY CHECKS

1. Ensure you are familiar with the operation of the hydraulic press.
2. Check for any hydraulic fluid leaks.
3. The press table must be clean and steel weights are flat and secure on press table.
4. Any forming die or cutting die must be inspected for safe use i.e. no cracks.
5. Ensure safety glasses or goggles are available and are worn by all persons in the vicinity.
6. Any test piece, project or material (work piece) to be pressed must be of an appropriate thickness and safe to use on this equipment.
7. Faulty equipment must not be used. Immediately report suspect machinery.

OPERATIONAL SAFETY CHECKS

1. Place your test piece, project or material (work piece) securely on the press table.
2. Ensure the pressure valve is closed before operation.
3. Use the press handle, in a pumping action, to slowly lower the press hammer.
4. Use your shoulder muscles when operating – NOT your lower back.
5. Keep hands and fingers away from all clamping and moving parts.
6. Carefully and accurately align the press hammer face with the work piece for even force to be applied.
7. Once the press hammer makes contact with the work piece, closely watch the PSI gauge and note the pressure applied.
8. Once the work piece is pressed sufficiently, release the hammer pressure at the release valve.
9. DO NOT apply excessive force with the press.

HOUSEKEEPING

1. After use, clean the press down and return any tools and equipment to the appropriate storage areas – including the press handle.
2. Place all scrap or waste in the appropriate bin.

POTENTIAL HAZARDS

- Beware of high forces applied
- Pinch and squash
- Potentially uneven forces being applied to the work piece
- Eye injuries – flying or shattering objects
- Laceration injuries

2.3 LIFTING INSTRUCTIONS

On the day that the machine arrives, make sure that a crane or forklift with sufficient capacity is available to unload the machine from the vehicle. Ensure access to the chosen site is clear and that doors and ceilings are sufficiently high and wide enough to receive the machine.

To handle the machine, the slings should be positioned so the machine is level when lifted. When using slings please take note of the sling angle and the loads that apply

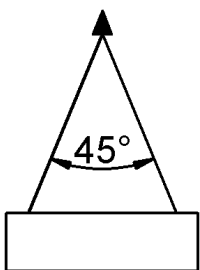

FIG 2.1.

When the slings are at a 45° angle then each sling is carrying the equivalent of 50% of load weight. (Fig.2.1).

When the slings are at a 90° angle then each sling will have a weight equal to 75% of the load on each sling. (Fig 2.2)

Note! The manufacturer recommends not to exceed 90° angle

FIG 2.2

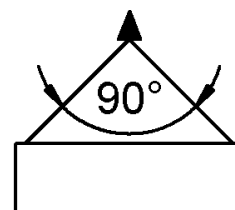

LIFTING POINTS

When lifting the machine only certified lifting slings should be used. (Fig.2.3)

Ensure that when lifting, the machine does not tip over.

Check that the lifting slings do not interfere with the hydraulic pipes.

Failure to follow these instructions could cause damage to the machine

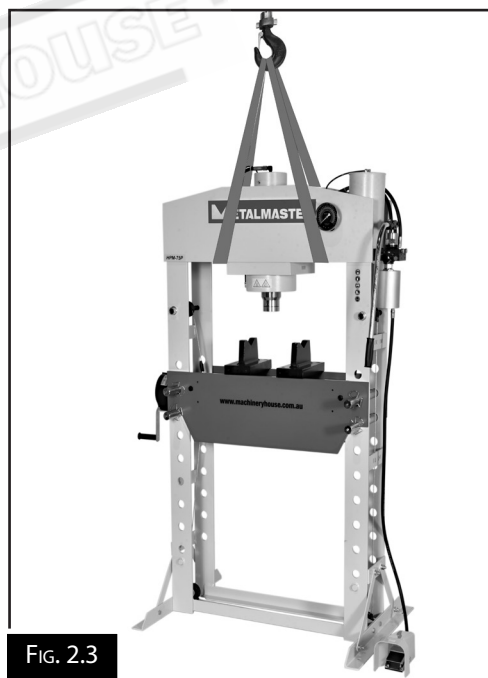

FIG. 2.3

	<p style="text-align: center;">!</p> <p style="text-align: center;">WARNING</p> <p><i>This machine and its parts are heavy! Serious personal injury may occur if safe moving methods are not used. To reduce the risk of a lifting or dropping injury, ask others for help and use the correct lifting equipment.</i></p>
--	---

3. INSTALLATION

A flat and clear area with plenty of lighting is required to assemble the machine. Unpack all the items ready to assemble.

IMPORTANT: We strongly recommend that the press be firmly secured to a firm and level floor using expansion bolts (not supplied). Holes are provided in the base supports for this purpose.

IMPORTANT: Do not locate your press where it will be open to the elements, as severe weather conditions will damage the hydraulic parts.

The position where your machine is operated is important for safe operation and the longevity of its components. For best results, operate this machine in a dry environment that is free from excessive moisture, hazardous chemicals, airborne abrasives, or extreme conditions.

Extreme conditions for this type of machinery are generally those where the environment is subject to vibration, shocks, or bumps.

Children or untrained people may be seriously injured by this machine. Only install in an access restricted location.

Lighting around the machine must be adequate enough that operations can be performed safely.

3.1 SITE PREPARATION

When selecting the site for the machine, consider the largest size of workpiece that will be processed through the machine and provide enough space around the machine for operating the machine safely. Consideration should be given to the installation of auxiliary equipment. Leave enough space around the machine to open or remove doors/covers as required for the maintenance and service as described in this manual.

It is recommended that the machine is anchored to the floor to prevent tipping or shifting. It also reduces vibration that may occur during operation.

3.2 OPTIONS FOR MOUNTING

The machine is best mounted on a concrete slab. Masonry anchors with bolts are the best way to anchor the machinery, because the anchors sit flush with the floor surface, making it easy to unbolt and move the machine later, if needed. (Fig. 3.1)

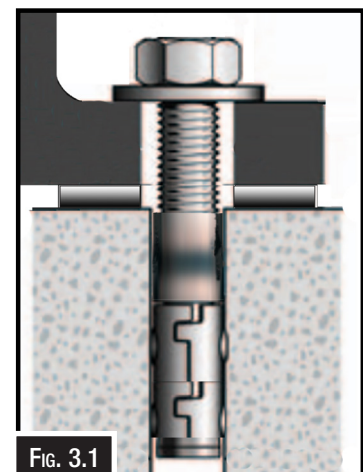

3.3 ASSEMBLY

Ensure the press and its components suffered no damage during transit and that all the parts are present. Should any loss or damage become apparent, please contact your local dealer immediately.

IMPORTANT: *Due to the weight of the press components, we recommend that you get assistance during assembly.*

IMPORTANT: *Do not locate your press where it will be open to the elements, as severe weather conditions will damage the hydraulic parts.*

To assemble the press follow the steps below:

1. Find a flat large area and lay out the parts ready for assembly. Make sure all the parts are there before you discard the packing.
2. Attach the feet and the bottom cross member to the side supports, using the M12X30 bolts, nuts and washers.(Fig.3.2)
3. Add the stay bars to each side and bolt into place.

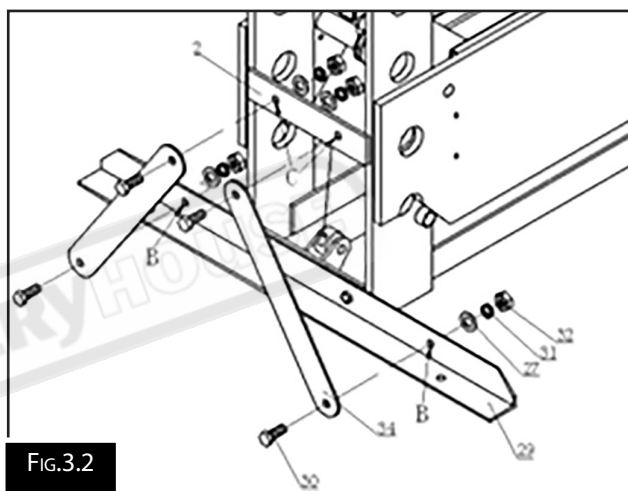

FIG.3.2

PRESSURE GAUGE ASSEMBLY

- 1 Assemble the nylon ring (72) to the gauge fitting (51), then screw the pressure gauge (50) on to the fitting and twist them tight together.

NOTE: *Make sure the fitting is as tight as possible, to ensure it will not leak.*

- 2, Place the gauge in the upper cross beam and attach the gauge fitting with the nut secure it to the beam.

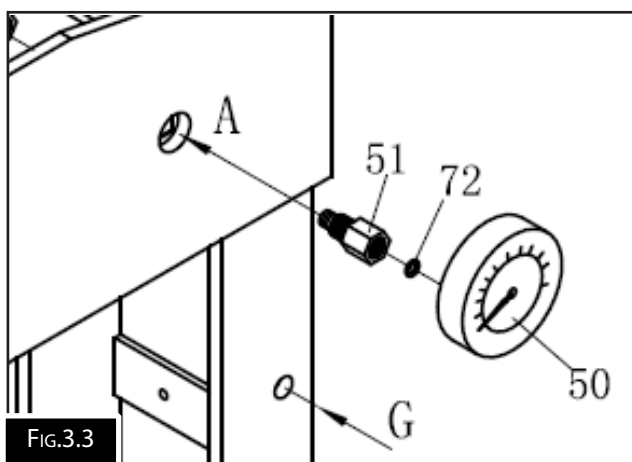

FIG.3.3

PUMP ASSEMBLY

1. Attach the pump assembly to the frame by using the bolts (M12X25), nuts and washers and tighten. (Fig. 3.4)
2. To avoid oil spillage from the oil hose (88), a plug (93) has been added in the oil hose when packing. To remove the plug, cut the oil hose with the plug about 10mm length. Then connect the oil hose (88) to 1/2" connector (94) (Fig. 3.5). Once the oil supply hose is connected, open the oil tank valve to allow the flow of oil and check for leaks.
3. Remove the plug of connector (#97 #98) and oil hose (#78 #79), then connect the oil hose 1 (#78) and oil hose 2 (#79) to connector (98) and connector (99) and tighten it. (Fig. 3.6)

NOTE: make sure the o-rings are in the grooves of connector (97) & (98) before assembling the two oil hoses.

4. Fix the selector lever (99) on the selector valve on the pump (80). (Fig. 3.7)

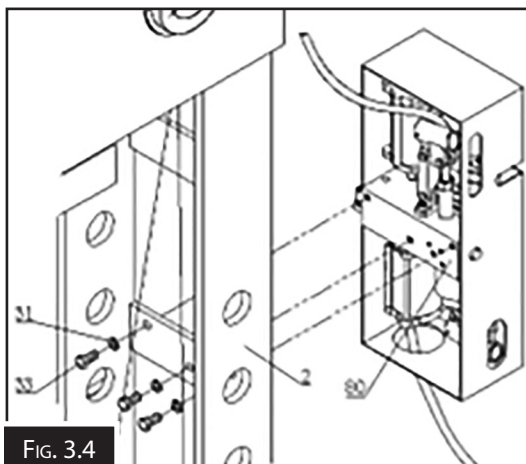

FIG. 3.4

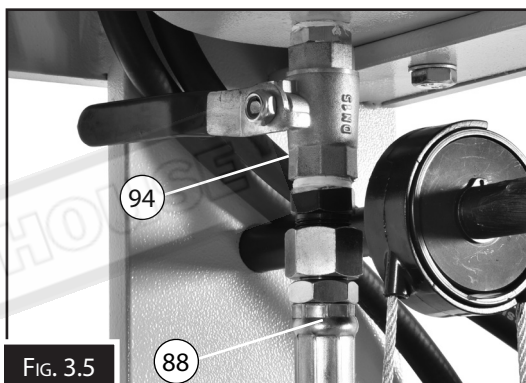

FIG. 3.5

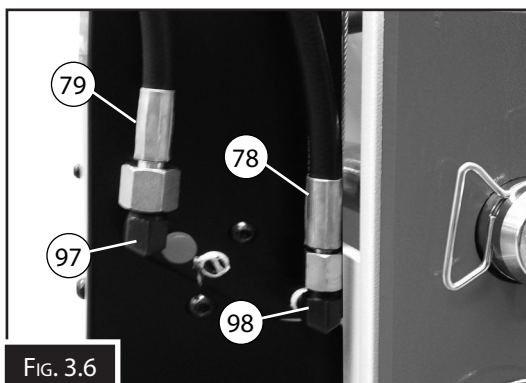

FIG. 3.6

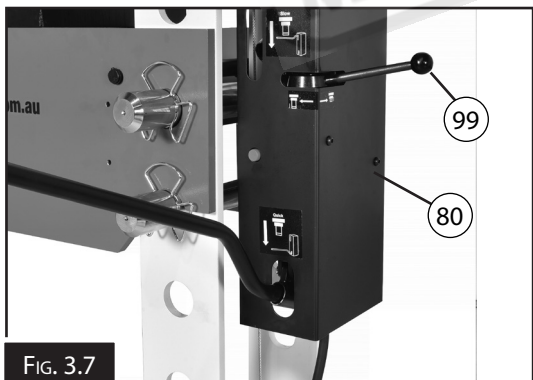

FIG. 3.7



WARNING.

A hydraulic hose burst can have devastating effects. Hydraulic fluid has the capacity to travel at lightning speed. Hydraulic fluid in the eyes can cause blindness or hydraulic poisoning. Always wear safety glasses

4. OPERATION

4.1 COMMISSIONING

Before the first use, ensure the machine is fixed to the floor that is a flat surface. Ensure that sufficient lighting is provided.

1. Pour a teaspoon of good quality, air tool oil into the air supply inlet of the lift control valve.
2. Connect the press to the air supply and operate for 3 seconds to evenly distribute the lubricant.

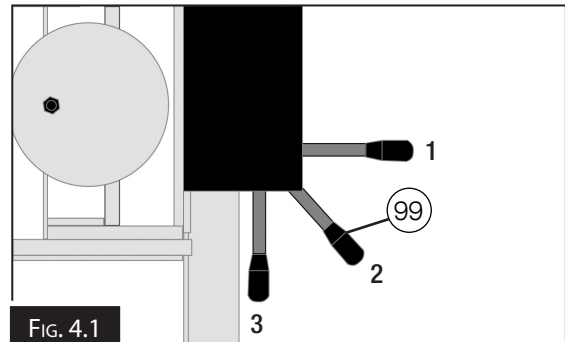

FIG. 4.1

PURGING THE QUICK OPERATION SYSTEM

1. Move the lever of the selector valve (#99) to position 2. (Fig. 4.1)

NOTE:When the handle lever (99) in position 1, the piston rod is retracting.

When the lever in position 2, the piston rod will stop moving.

When the handle lever in position 3, the piston rod is extending.

2. Insert the pump handle (50) into the socket of the quick pump socket. Operate the pump no less than twenty times to eliminate any air in the system. (Fig. 4.2)



FIG. 4.2

3. Turn the control lever (99) to position 3 (Fig. 4.3) and check if the ram is working smoothly. If the ram is working properly, the air purge is finished, if not, repeat the process.

PURGING THE SLOW OPERATION SYSTEM

1. Move the lever of the selector valve (#99) to position 2. (Fig. 4.1)
2. Insert the pump handle (50) into the socket of the slow pump socket. Operate the pump no less than twenty times to eliminate any air in the system. (Fig. 4.3)



FIG. 4.3

3. Turn the control lever (99) to position 3 (Fig. 4.1) and check if the ram is working smoothly. If the ram is working properly, the air purge is finished, if not, repeat the process.

4.2 POSITIONING THE BED

1. Position the bed at the desired height, so that it will be as close as possible to the ram when the workpiece is mounted on it.
2. Using the winch, raise the bed and insert the supporting pins into the locating holes.

NOTE: When Turning the handle (12) clockwise, the working bed will lift

3. Replace the safety clips on both ends of the supporting pins.

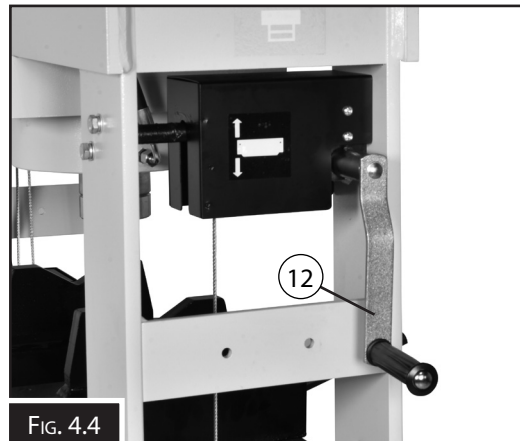

CAUTION *The bed height should only be raised or lowered making sure that a pin either side is placed in a hole below the bed to stop the bed if the winch or cable fail. Failure to work in this way may cause injury to the operator if the bed was to fall.*

4.3 POSITIONING THE RAM

The press is designed with a quick action method when moving the ram. It can be quickly positioned in either direction as required by sliding the ram baseplate along the cross-beam using the handle. (Fig.4.5)
The head is secured when pressure is applied to the ram.

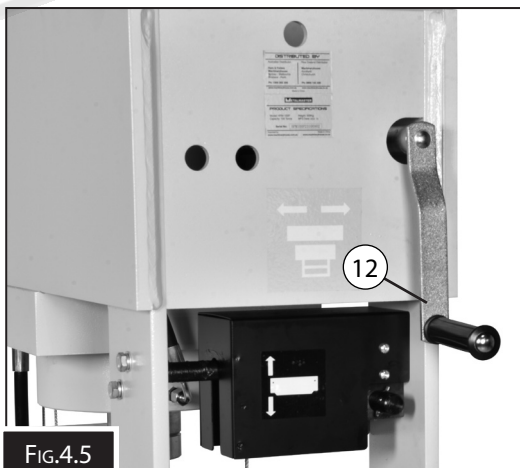

CAUTION *Always position the ram directly above the workpiece.*

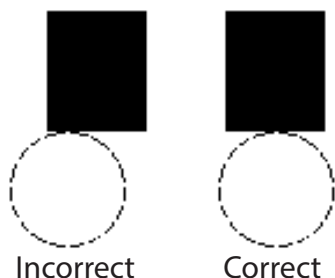

NOTE:
*Always make sure you are pressing with the whole ram.
Center the ram over the work, do not press with only the edge of the nose piece. This can cause injury by ejecting the part, or damage to the ram.*

4.4 PRESSING PROCESS

1. Place the workpiece on the bed. It must be completely stable and supported by packing or shims where required. Steel pressing plates are supplied, (Fig.4.6) locate on the bed. Place the workpiece on a combination of these to give it stability.

NOTE: Any packing pieces or shims used MUST be capable of withstanding the pressure that will be brought to bear, and MUST be of sufficient size with sufficient surface area, so as to avoid the possibility of slipping or springing out. Mating surfaces MUST be horizontal so that the force being exerted will NOT be at an angle.

2. Position the workpiece or slide the ram to one side so that the desired point of contact is directly beneath the centre of the ram.
3. Set the control valve lever to position 3. (Fig. 4.7)
4. When satisfied that the workpiece is correctly aligned and is completely stable in that position, slowly pump the handle or press the pedal so that the ram begins to exert pressure on the work piece. Continue to pump the handle or press the pedal whilst standing to the side. Do NOT stand directly in front of the work, and constantly monitor the process, ensuring the ram and work piece remain completely in line and there is no risk of slipping. Closely watch the PSI gauge and note the pressure applied. (Fig. 4.8)
5. When the process is complete, turn the release valve anticlockwise in small increments to release the ram pressure slowly to allow removal of the workpiece.

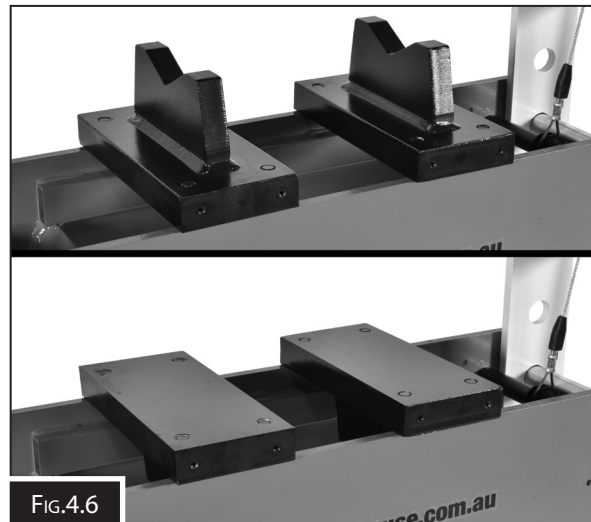

FIG.4.6



FIG.4.7

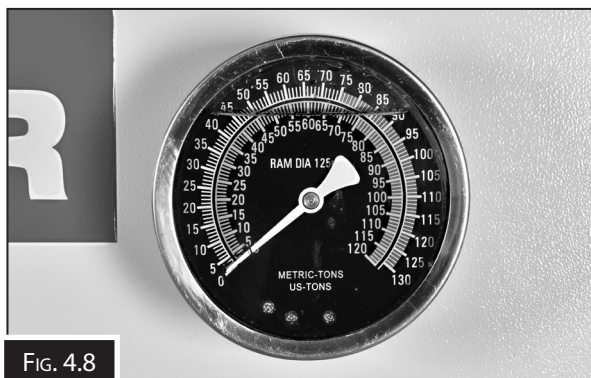



FIG. 4.8



WARNING.

Take care when operating this machine. Crush Points can occur between the Ram and the workpiece or between the workpiece and the table.

5. MAINTENANCE

- A visual inspection must be made before each use of the press, checking for leaking hydraulic fluid and damaged, loose, or missing parts.
- Owners and/or users should be aware that repair of this equipment requires specialized knowledge and facilities. It is recommended that a thorough annual inspection of the press be made and that any defective parts be replaced with genuine Metalmaster parts.
- Any press which appears to be damaged in any way, is found to be badly worn, or operates abnormally **SHOULD BE REMOVED FROM SERVICE** until the necessary repairs are made.
- If the press is not to be used for any length of time, store it with the ram retracted and the operating handle in the lowered position to protect the moving parts.

5.1 INSPECTION SCHEDULE

- Check daily for any unsafe conditions and fix immediately before using.
- Check that all the nuts and bolts are tight.
- Lubricate the threaded parts, such as pivot points and sliding devices.
- Check the hydraulic hoses and fittings for any leakage.
- Keep the area around machine clear of debris.
- Clean the outside of the press with a clean, soft cloth.
- When not in use, keep the press dry and covered. Ensure that the ram and piston are fully retracted to prevent rust or corrosion.
- If the press efficiency drops, purge the air from the hydraulic system. (See Page 14)

5.2 TROUBLESHOOTING

Problem	Probable Cause	Remedy
Pump unit will not work	Dirt on the valve seat/worn seals	Bleed pump unit or have unit overhauled with new seals
Pump will not produce pressure. Pump feels hesitant under load. Pump will not lower completely	Air-lock	Open the release valve and remove the oil filler plug. Pump the handle a couple of full strokes and close the release valve. Replace the filler plug.
Pump will not deliver pressure	Reservoir could be overfilled or have low oil level	Check oil level by removing the filler plug and topping up to the correct level.
Pump feels hesitant under load	Pump cup seal could be worn out	Have the cup seal replaced.
Pump will not lower completely	Air-lock	Release air by removing the filler plug

5.3 CHANGING THE HYDRAULIC OIL

HAFCO METALMASTER recommends to replace the hydraulic oil every 6 months of machine use.

NOTE IMPORTANT! Only fill with new, clean, light hydraulic oil. Under no circumstances use dirty oil.

1. When the press working efficiency is reduced, purge the air in the hydraulic system. (See Page 14)
2. Oil volume check: The operator can check if the oil volume is sufficient by pumping the handle to check if the piston ram can extend fully (300mm).
3. If the oil volume is low, add hydraulic oil to the oil tank.
4. Use Gulf Western ISO 46 Hi-Temp Hydraulic oil or equivalent.
5. Filter the oil to remove any possible dirt.
6. Put the piston in to its maximum upper position. Remove the screw (58) on the top of the oil tank, and add hydraulic oil. Once completed, then replace and tighten the screw.
7. After adding the oil, perform air purge according to process on page 14



Order Code: 0002



WARNING.

A hydraulic hose burst can have devastating effects. Hydraulic fluid has the capacity to travel at lightning speed. Hydraulic fluid in the eyes can cause blindness or hydraulic poisoning. Always wear safety glasses



WARNING

The machine is the sole responsibility of the owner for its safe use. This responsibility includes but is not limited to proper installation in a safe environment, personnel training, proper inspection and maintenance, manual availability and comprehension. The manufacturer will not be held liable for injury or property damage from negligence, improper training, machine modifications or misuse.

SPARE PARTS SECTION

Hydraulic & Pneumatic Shop Press

Model

HPM-100P

Order Code P156

EDITION No : HPH-100P-1
DATE OF ISSUE : 01-2024

The following section covers the spare parts diagrams and lists that were current at the time this manual was originally printed. Due to continuous improvements of the machine, changes may be made at any time without notification.

HOW TO ORDER SPARE PARTS

1. Have your machines model number, serial number & date of manufacture on hand, these can be found on the specification plate mounted on the machine
2. A scanned copy of your parts list/diagram with required spare part/s identified.

NOTE: SOME PARTS MAY ONLY BE AVAILABLE AS AN ASSEMBLY

3. Go to www.machineryhouse.com.au/contactus and fill out the inquiry form attaching a copy of scanned parts list.

SPARE PARTS DIAGRAM

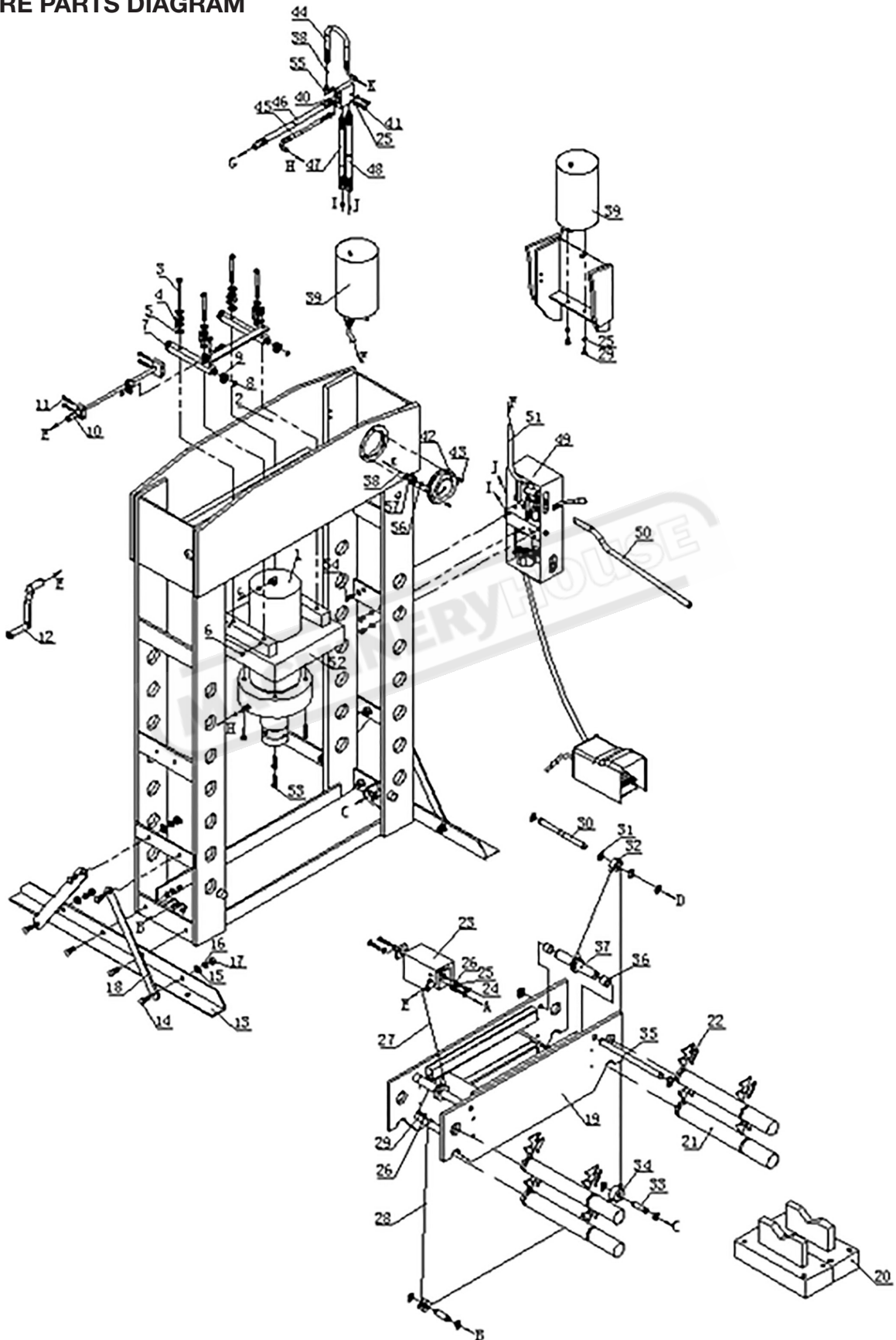

MAIN SPARE PARTS LIST

No.	Description	Qty	No.	Description	Qty
1	Ram Assy	1	30	Roller Pin	1
2	Body Frame	1	31	Circlip Ø20	8
3	Hex Bolt M12*130	4	32	Roller With Cover III	1
4	Spring Cove	8	33	Roller Pin 2	2
5	Spring	4	34	Roller With Cover	2
6	Hexagon skt set screw M8*10	4	35	Lifting Bar	2
7	Steel Tube II	2	36	Tube 2	4
8	Circlip Ø17	4	37	Bushing	1
9	Ball Bearing GB/T276-6203	4	38	O-ring 9*1.9	2
10	Ram Moving Equipment	1	39	Oil Tank	1
11	Hexagon Screw M8*45	4	40	Adapter	1
12	Handle Part	1	41	Hex Screw M10*40	2
13	Base	2	42	Pressure Gauge	1
14	Hex Bolt M12*30	12	43	Screw M5*8	3
15	Washer GB/T95-Ø12	12	44	Oil Hose 1	1
16	Spring Washer GB/T93-Ø12	15	45	Oil Hose (Down)	1
17	Hex Nut M12	12	46	Oil Hose 3	1
18	Support	4	47	Oil Hose 1	1
19	Working Bed	1	48	Oil Hose 2	1
20	Heel Block	2	49	Pump Assy	1
21	Pin	4	50	Handle Tube	1
22	Circlip	8	51	Oil Hose	1
23	Working Bed Moving Equipment	1	52	Under Plate	1
24	Hex Screw M10*30	4	53	Hexagon Screw M12*45	4
25	Spring Washer Ø10	8	54	Hex Bolt M12*25	3
26	Washer Ø10	5	55	Fitting	1
27	Cable 1.6M	1	56	Nylon Ring	1
28	Cable 4.3M	1	57	Connecting Nut	1
29	Hex Screw M10*20	3			

NOTE: SOME INDIVIDUAL PARTS MAY ONLY BE AVAILABLE AS AN ASSEMBLY

PUMP SPARE PARTS DIAGRAM

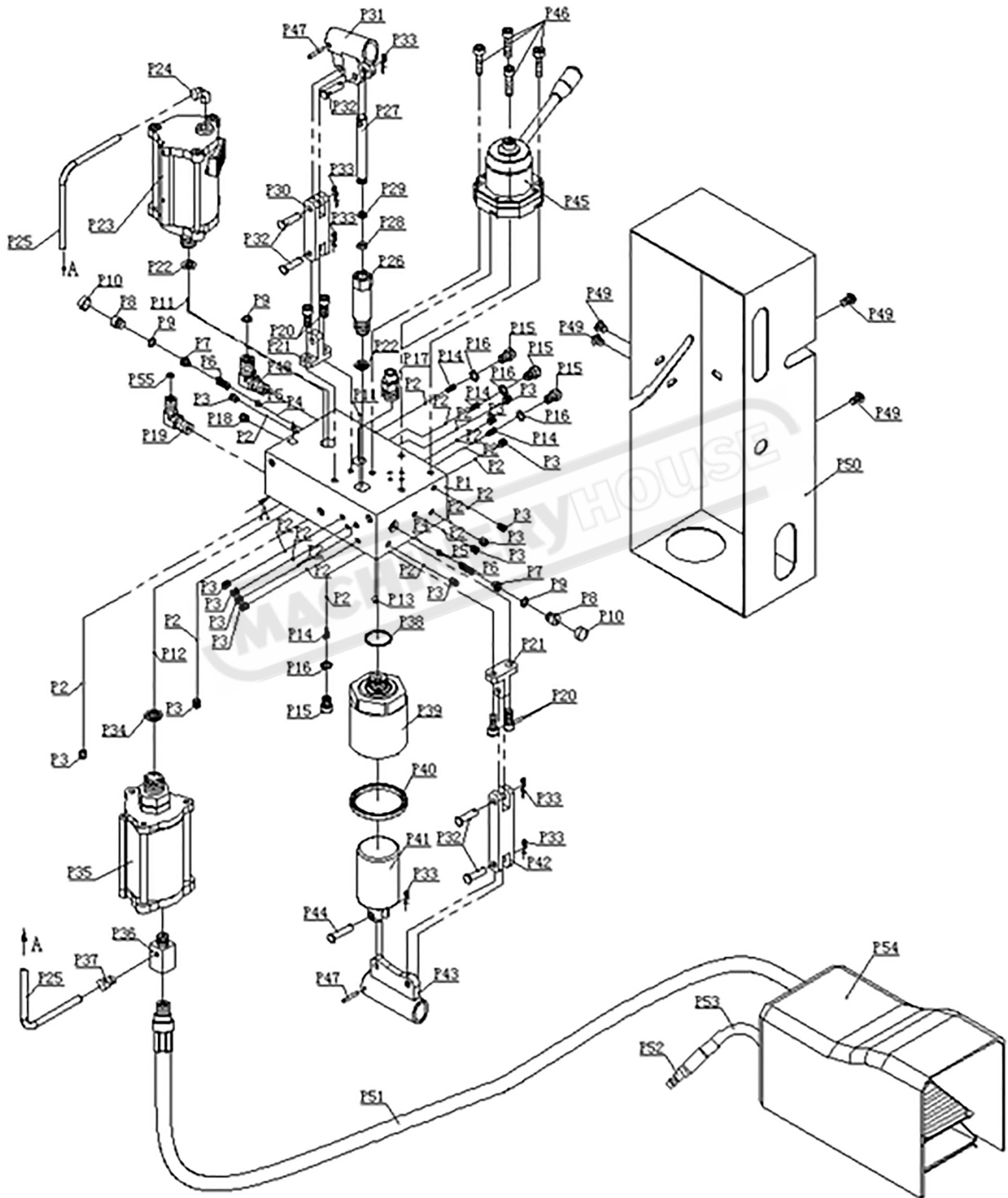

PUMP SPARE PARTS LIST

No.	Description	Qty	No.	Description	Qty
P1	Pump	1	P29	Circlip	1
P2	Steel Ball Ø6.0000	18	P30	Connecting Bar	1
P3	Hexagon Skt Set Screw M8*10	14	P31	Handle Socket	1
P4	Steel Ball Ø3.0000	2	P32	Pin8*30	5
P5	Steel Ball Base	2	P33	R-Pin	6
P6	Spring	2	P34	Copper Washer	1
P7	Screw	2	P35	Air Motor	1
P8	Plug Screw	2	P36	Branch Joint	1
P9	O-ring	2	P37	Connector	1
P10	Cover	2	P38	O-Ring 30*2	1
P11	Steel Ball Ø5.0000	2	P39	Big Pump Core Base	1
P12	Steel Ball Ø7.1438	1	P40	U-Ring NOK53*63*6	1
P13	Steel Ball Ø8.0000	1	P41	Big Pump Core	1
P14	Spring	4	P42	Big Connecting Bar	1
P15	Plug Screw	4	P43	Handle Socket For Low Pressure	1
P16	Copper Washer TT-245	4	P44	Pin 8*35	1
P17	NPT1/2" Connector	1	P45	Manual selector valve	1
P18	NPT1/4" Plug	1	P46	Hexagon Screw M8*35	4
P19	Fitting	1	P47	Spring Pin Ø 4*26	2
P20	Hexagon Bolt M8*20	4	P48	Fitting	1
P21	Connecting Rod Base	2	P49	Flat-head Screw GB70.2-M8*10	4
P22	Copper Washer TT-244	2	P50	Pump Cover	1
P23	Air Motor	1	P51	Air Hose 1	1
P24	NPT1/4"-8 Connector	1	P52	Air Hose Joint	1
P25	PU Tube 8*6	1	P53	Air Hose 2	1
P26	Pump Core Base	1	P54	Air Valve	1
P27	Pump Core	1	P55	O-Ring 9*1.9	1
P28	O-ring 6.5*3	1			

NOTE: SOME INDIVIDUAL PARTS MAY ONLY BE AVAILABLE AS AN ASSEMBLY

RAM SPARE PARTS DIAGRAM

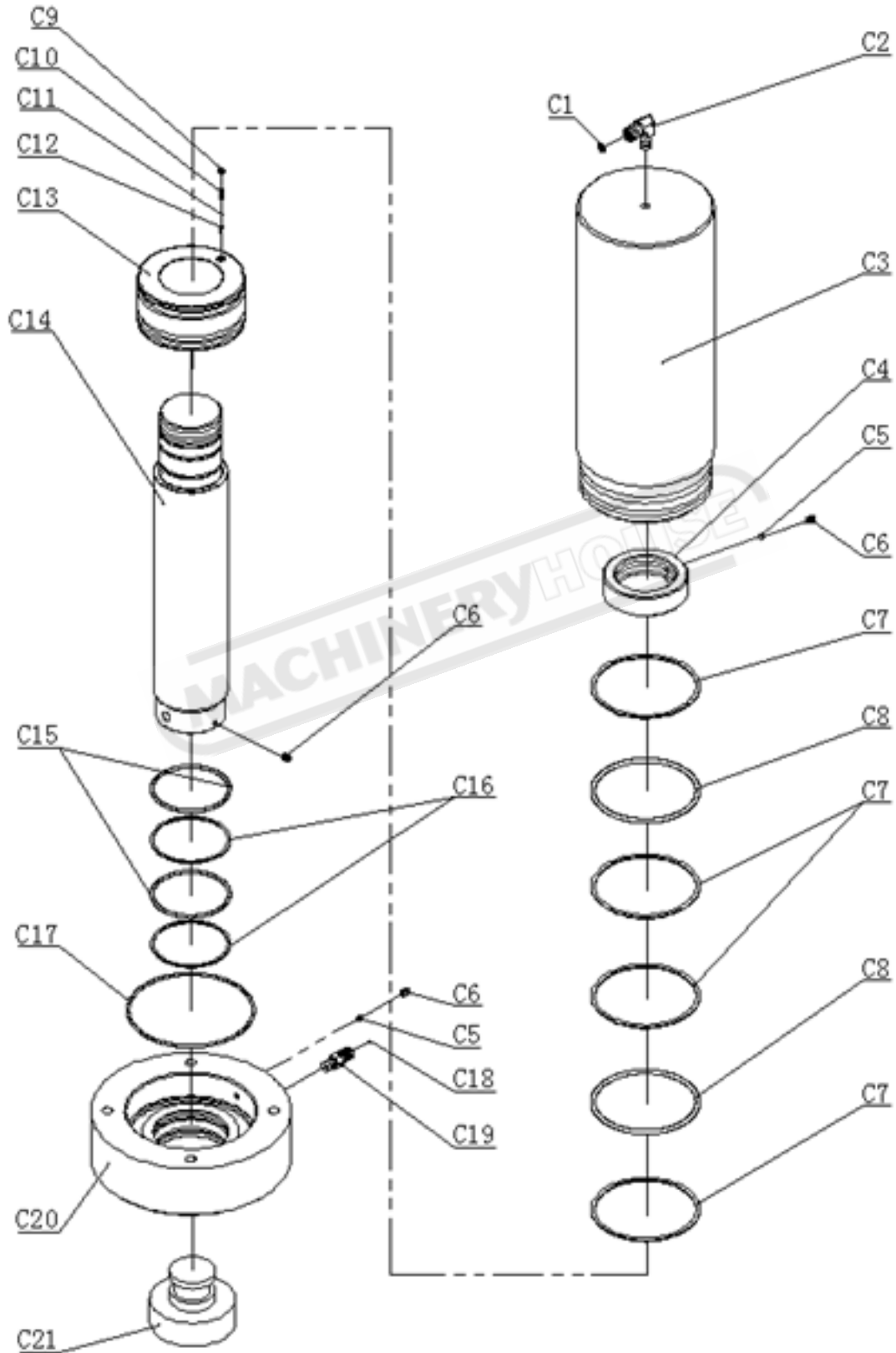

PUMP SPARE PARTS LIST

No.	Description	Qty
C1	O-ring 8*2	1
C2	Fitting	1
C3	Cylinder	1
C4	Nut	1
C5	Nylon Block	2
C6	Hexagon Skt Set Screw M8*10	3
C7	PTFE Washer	4
C8	O-ring GB3452.1-129.6*5.7	2
C9	Screw	1
C10	Spring	1
C11	Steel Ball Ø4.7630	1
C12	Valve Rod	1
C13	Piston	1
C14	Piston Rod	1
C15	O-ring GB3452.1-96*4	2
C16	PTFE Washer	2
C17	O-ring GB3452.1-158.34*3.53	1
C18	O-ring GB1235-9*1.9	1
C19	Connector I	1
C20	Ring For Ram	1
C21	Serrated Saddle	1

NOTE: SOME INDIVIDUAL PARTS MAY ONLY BE AVAILABLE AS AN ASSEMBLY



WARNING!

Serious injury or death can result from using this machine BEFORE understanding its controls and related safety information. DO NOT operate, or allow others to operate, the machine until the information is understood.

VALVE SPARE PARTS

No.	Description	Qty
V1	Hexagon Screw	1
V2	T Washer	1
V3	Key	1
V4	Moving Cover	1
V5	Handle	1
V6	Pin	1
V7	Spring	1
V8	Steel Ball	1
V9	Copper Washer	1
V10	O-Ring	1
V11	Valve Jacket	1
V12	Ball Bearing	1
V13	Valve Plug	1
V14	Hexagon Socket Set Screw	1
V15	Steel Ball	1
V16	Spring	1
V17	O-Ring	3
V18	PTFE Washer	3
V19	Slide Valve	1
V20	Connector	1
V21	O-Ring	1
V22	Valve Plate	1
V23	Hexagon Screw	4
V24	O-Ring	4
V25	O-Ring	1

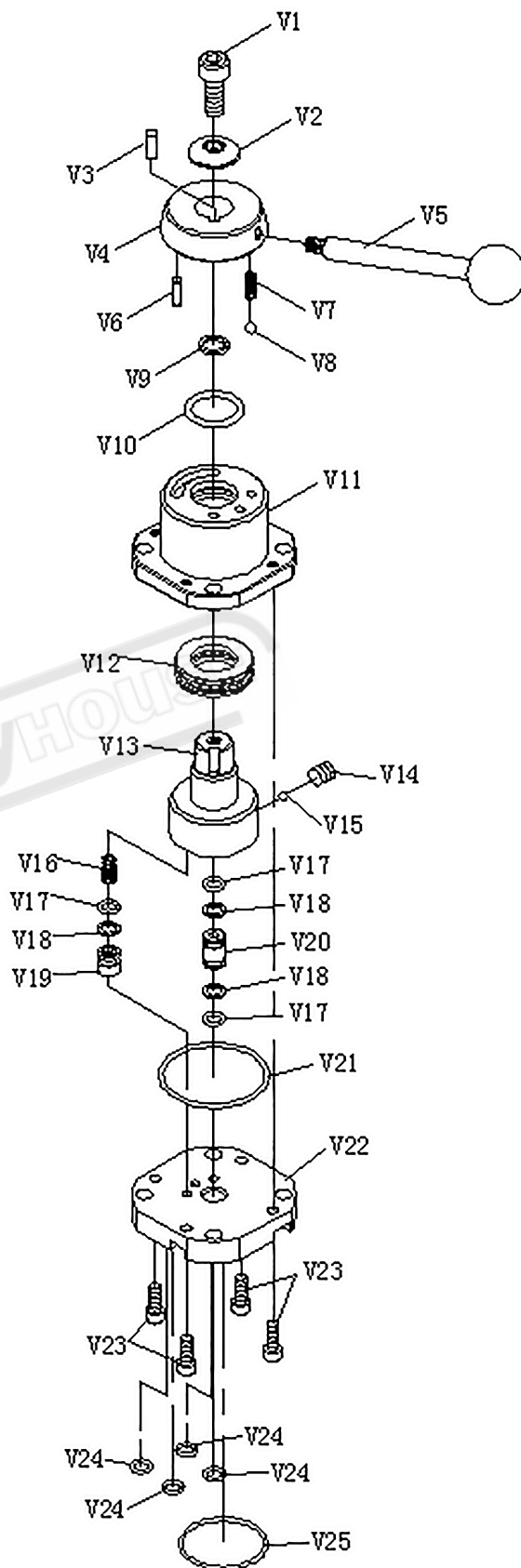
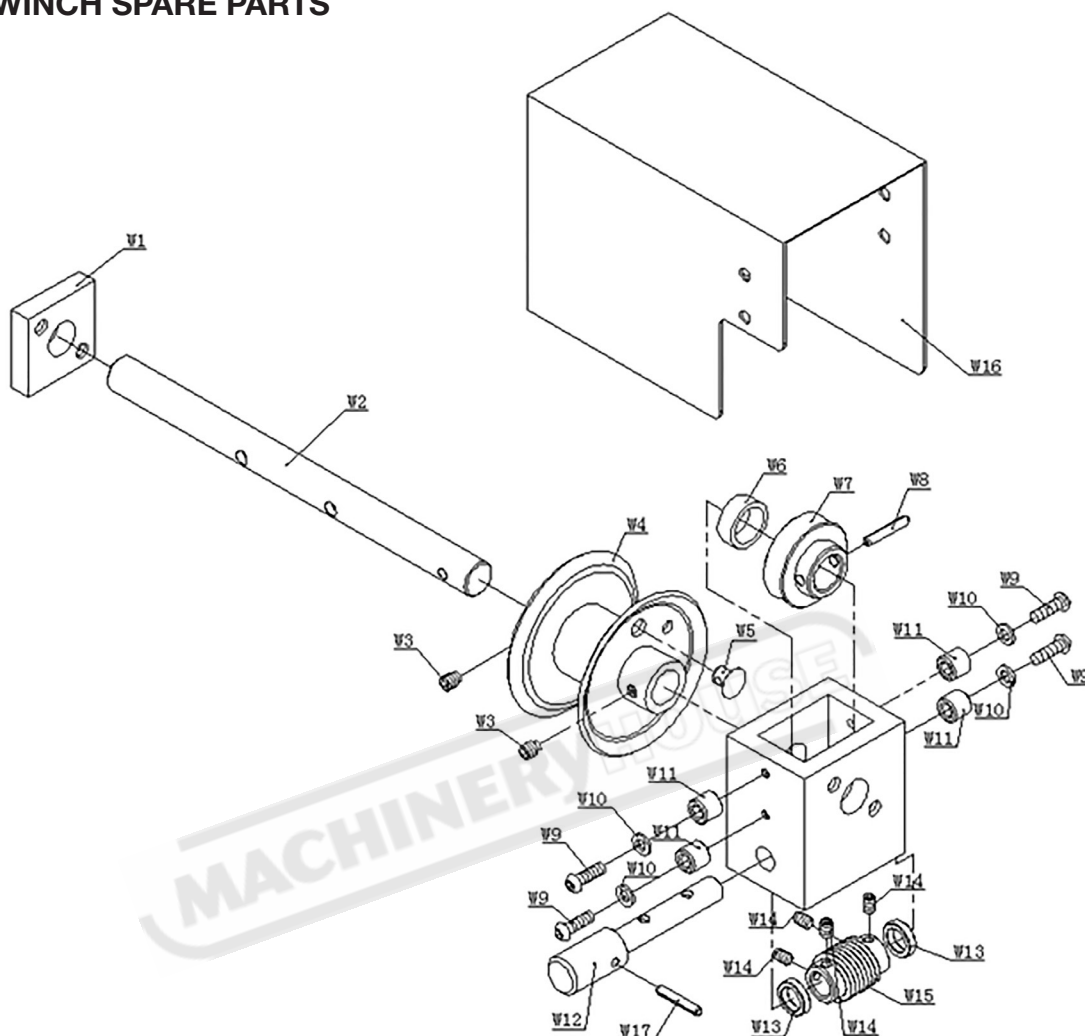

TABLE WINCH SPARE PARTS



No.	Description	Qty	No.	Description	Qty
W1	Support Plate	1	W10	Washer Ø10	4
W2	Worm Shaft	1	W11	Washer	4
W3	Hexagon Screw M8*10	2	W12	Worm Shaft	1
W4	Winch	1	W13	Worm Washer	2
W5	Rivet	1	W14	Hexagon Skt Set Screw M6*10	4
W6	Worm Pad	1	W15	Worm	1
W7	Worm	1	W16	Winch Cover	1
W8	Spring Pin Ø6*30	1	W17	Spring Pin Ø5*30	1
W9	Hexagon Screw 6*20	4			

NOTE: SOME INDIVIDUAL PARTS MAY ONLY BE AVAILABLE AS AN ASSEMBLY

RAM MOVING SCREW SPARE PARTS

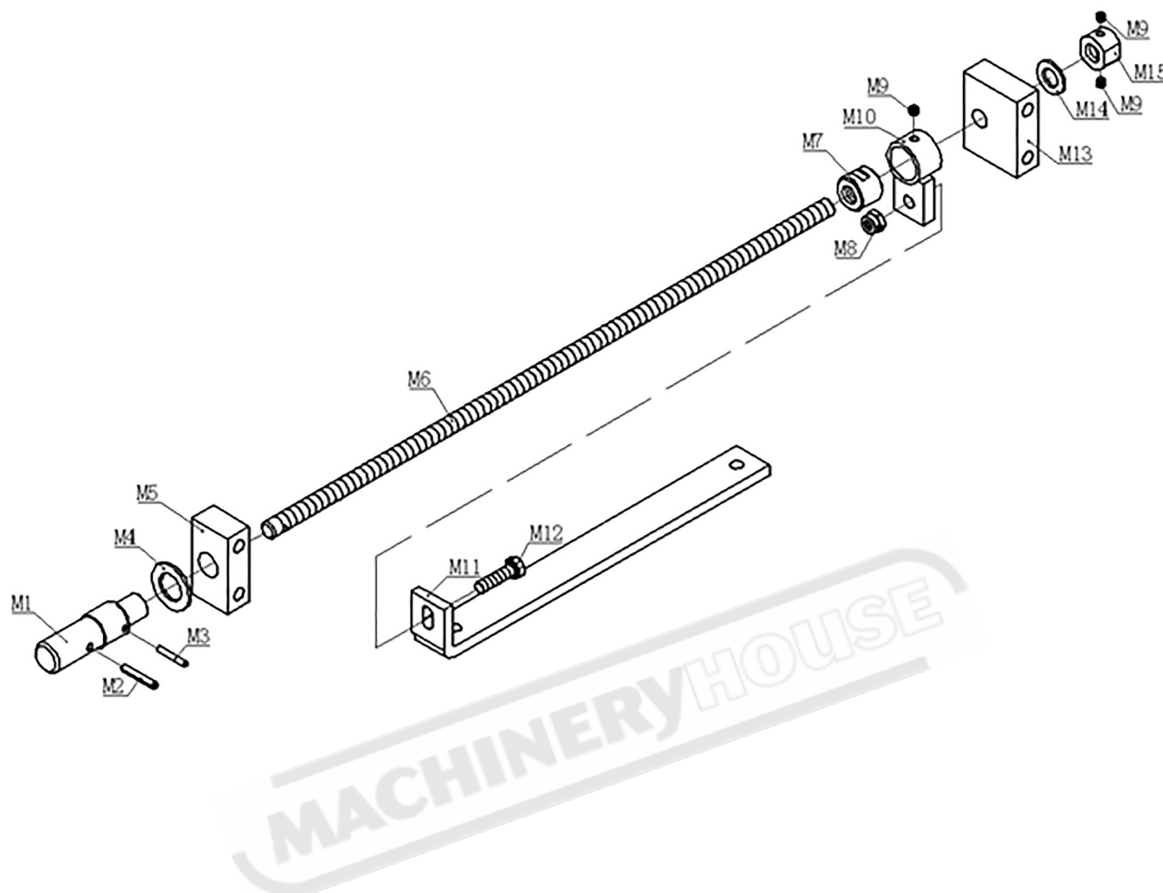

No.	Description	Qty	No.	Description	Qty
M1	Worm Connecting Shaft	1	M9	Hexagon Skt Set Screw M6*5	3
M2	Spring Pin Ø5*30	1	M10	Nut Cover	1
M3	Spring Pin Ø4*25	1	M11	Connecting Bar	1
M4	Washer Ø18	1	M12	Hex Bolt M8*30	1
M5	Support Base 2	1	M13	Screw Base 1	1
M6	Screw	1	M14	Washer Ø12	1
M7	Nut	1	M15	Locking Nut	1
M8	Damping Nut M8	1			

NOTE: SOME INDIVIDUAL PARTS MAY ONLY BE AVAILABLE AS AN ASSEMBLY

WARNING

General Machinery Safety Instructions

Machinery House
requires you to read this entire Manual before using this machine.

- 1. Read the entire Manual before starting machinery.** Machinery may cause serious injury if not correctly used.
- 2. Always use correct hearing protection when operating machinery.** Machinery noise may cause permanent hearing damage.
- 3. Machinery must never be used when tired, or under the influence of drugs or alcohol.** When running machinery you must be alert at all times.
- 4. Wear correct Clothing.** At all times remove all loose clothing, necklaces, rings, jewelry, etc. Long hair must be contained in a hair net. Non-slip protective footwear must be worn.
- 5. Always wear correct respirators around fumes or dust when operating machinery.** Machinery fumes & dust can cause serious respiratory illness. Dust extractors must be used where applicable.
- 6. Always wear correct safety glasses.** When machining you must use the correct eye protection to prevent injuring your eyes.
- 7. Keep work clean and make sure you have good lighting.** Cluttered and dark shadows may cause accidents.
- 8. Personnel must be properly trained or well supervised when operating machinery.** Make sure you have clear and safe understanding of the machine you are operating.
- 9. Keep children and visitors away.** Make sure children and visitors are at a safe distance for you work area.
- 10. Keep your workshop childproof.** Use padlocks, Turn off master power switches and remove start switch keys.
- 11. Never leave machine unattended.** Turn power off and wait till machine has come to a complete stop before leaving the machine unattended.
- 12. Make a safe working environment.** Do not use machine in a damp, wet area, or where flammable or noxious fumes may exist.
- 13. Disconnect main power before service machine.** Make sure power switch is in the off position before re-connecting.
- 14. Use correct amperage extension cords.** Undersized extension cords overheat and lose power. Replace extension cords if they become damaged.
- 15. Keep machine well maintained.** Keep blades sharp and clean for best and safest performance. Follow instructions when lubricating and changing accessories.
- 16. Keep machine well guarded.** Make sure guards on machine are in place and are all working correctly.
- 17. Do not overreach.** Keep proper footing and balance at all times.
- 18. Secure workpiece.** Use clamps or a vice to hold the workpiece where practical. Keeping the workpiece secure will free up your hand to operate the machine and will protect hand from injury.
- 19. Check machine over before operating.** Check machine for damaged parts, loose bolts, Keys and wrenches left on machine and any other conditions that may effect the machines operation. Repair and replace damaged parts.
- 20. Use recommended accessories.** Refer to instruction manual or ask correct service officer when using accessories. The use of improper accessories may cause the risk of injury.
- 21. Do not force machinery.** Work at the speed and capacity at which the machine or accessory was designed.
- 22. Use correct lifting practice.** Always use the correct lifting methods when using machinery. Incorrect lifting methods can cause serious injury.
- 23. Lock mobile bases.** Make sure any mobile bases are locked before using machine.
- 24. Allergic reactions.** Certain metal shavings and cutting fluids may cause an allergic reaction in people and animals, especially when cutting as the fumes can be inhaled. Make sure you know what type of metal and cutting fluid you will be exposed to and how to avoid contamination.
- 25. Call for help.** If at any time you experience difficulties, stop the machine and call you nearest branch service department for help.

WARNING

Hydraulic Press Safety Instructions

Machinery House
requires you to read this entire Manual before using this machine.

- 1. Maintenance.** Check oil levels and fill to correct oil levels if necessary. Apply oil to surface of ram to maintain good lubrication.
- 2. Press Condition.** Press must be maintained for a proper working condition. Never operate a Press that has low oil levels, damaged or worn parts. Scheduled routine maintenance should be performed on a scheduled basis. Check all hoses, pressure head, and support rods for cracks or damage. Replace if necessary.
- 3. V-Block Condition.** Never operate a Press with damaged or badly worn V-blocks. Replace if required.
- 4. Hand Hazard.** Keep hands away from the pressure head and out of support rod holes, under any circumstances, while the machine is in operation mode. Serious injury can occur.
- 5. Gloves & Glasses.** Always wear leather gloves and approved safety glasses when using this machine.
- 6. Work area hazards.** Keep the area around the Press clean from oil, tools, objects & chips. Pay attention to other persons in the area and know what is going on around the area to ensure unintended accidents.
- 7. Overloading Press.** Do not exceed the press capacity indicated on the gauge.
- 8. Warning Labels.** Take note of any warning labels on the machine and do not remove them.
- 9. Material Hazard.** Do not compress springs or other objects that could be ejected from the press. Do not compress objects that could shatter. Serious injury can occur.
- 10. Secure Press.** Make sure you bolt the machine down so it is secure when in operation.
- 11. Use Correct Air Pressure** Exceeding the maximum PSI rating of Press may cause unpredictable operation, injury and damage to machine. If this rating is not stated in manual suggest NOT to exceed 125psi.
(Applies to Pneumatic model only).
- 12. Disconnect Air Pressure** before servicing Press, or leaving unattended.
(Applies to Pneumatic model only).
- 13. Air Hose - Trip Hazard** Hoses can easily become a tripping hazard when laid across the floor in a disorganized fashion.
(Applies to Pneumatic model only).
- 14. Call for help.** If at any time you experience difficulties, stop the machine and call your nearest branch service department for help.

PLANT SAFETY PROGRAM

NEW MACHINERY HAZARD IDENTIFICATION, ASSESSMENT & CONTROL

Hydraulic Press

Developed in Co-operation Between A.W.I.S.A and Australia Chamber of Manufactures
This program is based upon the Safe Work Australia, Code of Practice - Managing Risks of Plant in the Workplace (WHSA 2011 No10)

Item No.	Hazard Identification	Hazard Assessment	Risk Control Strategies (Recommended for Purchase / Buyer / User)
B	CRUSHING	HIGH	Do not exceed maximum capacity. Check equipment for damage prior to use. Wear safety boots. Never put any part of your body between hydraulic ram and material. Always support material properly on hydraulic press. Ensure press is bolted down on level solid ground. Ensure table is as close as possible to ram and support pins are correctly positioned before using. Do not exceed recommended maximum PSI rating. (applies to Pneumatic model only) Use equipment in the correct manner as to avoid parts being ejected out under pressure.
C	CUTTING, STABBING OR PUNCTURING	MEDIUM	Use equipment in the correct manner as to avoid parts being ejected out under pressure.
E	STRIKING	MEDIUM	Use equipment in the correct manner as to avoid parts being ejected out under pressure.
G	HIGH PRESSURE AIR	MEDIUM	Disconnect air supply to press prior to checks or maintenance. Do not exceed recommended maximum PSI rating. (applies to Pneumatic model only)
Plant Safety Program to be read in conjunction with manufactures instructions			



www.machineryhouse.com.au



www.machineryhouse.co.nz

Authorised and signed by:

Safety officer: 

Manager: 

Revised Date: 4th December 2017